

USE AND MAINTENANCE INSTRUCTION MANUAL

Bio 80

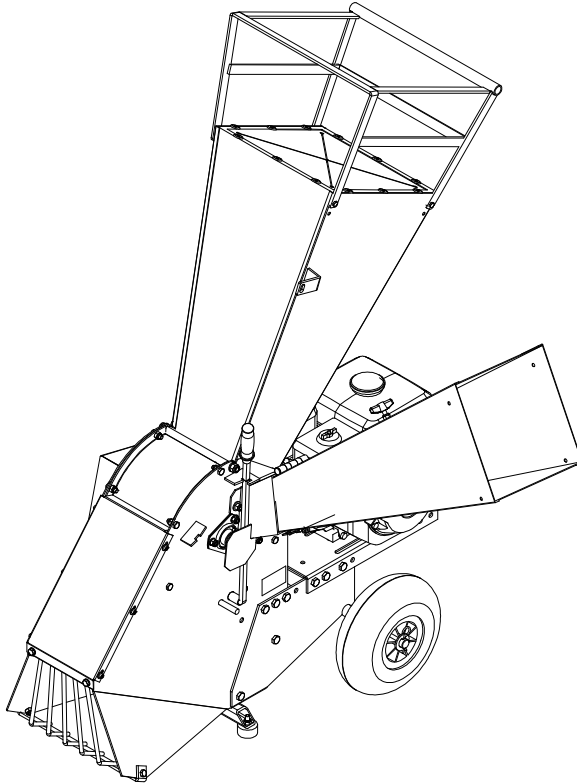

TRANSLATION OF THE ORIGINAL INSTRUCTIONS

BEFORE USING THE MACHINE, READ THE INSTRUCTION MANUAL.

Caravaggi Srl - Via Monte Adamello, 20 - 25037 Pontoglio (BS) - ITALY

EC DECLARATION OF CONFORMITY



The Company
CARAVAGGI Srl

REGISTERED OFFICE, FACTORY AND ADMINISTRATION :
20, Via Monte Adamello, 25037 Pontoglio (BS), ITALY

Declares under its own responsibility that the
Bio 80 B BIOSHREDDER

Model **Bio 80 petrol**
Bio 80 for two-wheel tractor

Serial number: **see rating plate**

Year built: **see rating plate**

Complies with all the provisions regarding the following European Directives:

Machinery Directive 2006/42/CE as an amendment to Directive 95/16/CE
Directive 2004/108/CE on the harmonisation of the laws of member countries relating to electromagnetic compatibility.

Directive 2006/95/CE on the harmonisation of the laws of member countries relating to electrical equipment designed for use within certain voltage limits.

And since the machine has been adapted to the following harmonized standards and specifications, where applicable:

UNI EN ISO 12100: Safety of machinery – Basic concepts, general principles of design – Basic terminology, methodology, technical principles.

UNI EN ISO 4254-1: Agricultural machinery - Safety - Part 1: General requirements.

UNI EN 13683: Safety – Powered shredders/chippers.

ISO 11684: Tractors, machinery for agriculture and forestry, powered lawn and garden equipment – Safety signs and hazard pictorials – General principles.

Person authorised to draw up the declaration of conformity: **Valerio Gianpaolo Caravaggi**

The Legal Representative
(Valerio Gianpaolo Caravaggi)

CARAVAGGI s.r.l.
Via Monte Adamello, 20
25037 PONTOGGIO (BS) Italia
Telefono 030.7470184
Partita IVA 01743270984

Pontoglio, 01 / 01 / 2012

EC DECLARATION OF CONFORMITY



The Company
CARAVAGGI Srl

REGISTERED OFFICE, FACTORY AND ADMINISTRATION :
20, Via Monte Adamello, 25037 Pontoglio (BS), ITALY

Declares under its own responsibility that the
Bio 80 E BIOSHREDDER

Model **Bio 80 Electric 3 HP 220 V / 4 HP 380 V**

Serial number: **see rating plate**

Year built: **see rating plate**

Complies with all the provisions regarding the following European Directives:

Machinery Directive 2006/42/CE as an amendment to Directive 95/16/CE
Directive 2004/108/CE on the harmonisation of the laws of member countries relating to electromagnetic compatibility.

Directive 2006/95/CE on the harmonisation of the laws of member countries relating to electrical equipment designed for use within certain voltage limits.

And since the machine has been adapted to the following harmonized standards and specifications, where applicable:

UNI EN ISO 12100: Safety of machinery – Basic concepts, general principles of design – Basic terminology, methodology, technical principles.

UNI EN ISO 4254-1: Agricultural machinery - Safety - Part 1: General requirements.

UNI EN 13683: Safety – Powered shredders/chippers.

CEI EN 60204-1: Safety of machinery – Electrical equipment of machines - Part 1: General rules.

ISO 11684: Tractors, machinery for agriculture and forestry, powered lawn and garden equipment – Safety signs and hazard pictorials – General principles.

Person authorised to draw up the declaration of conformity: **Valerio Gianpaolo Caravaggi**

The Legal Representative
(Valerio Gianpaolo Caravaggi)

CARAVAGGI s.r.l.
Via Monte Adamello, 20
25037 PONTOLIO (BS) (Cremona)
Tel/Fax 030.7479464
Partita IVA 01743270363

Pontoglio, 01 / 01 / 2012

1. HAZARD PICTORIALS

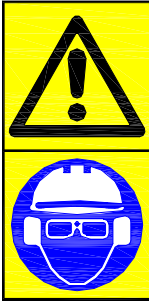

Warning!
Wear a hard hat, hearing protectors and protective glasses or goggles.



Warning!
Wear protective gloves.



Warning!
Wear safety shoes.



Warning!
Wear clothes that are suitable for work on machines with moving parts.



Warning!
Unplug from the mains before carrying out any maintenance.

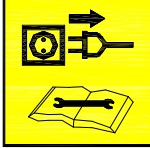

Warning!
Remove the engine spark plug before carrying out any maintenance.

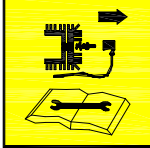

Warning!
Switch off the engine before carrying out any maintenance.

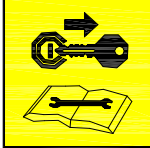

Hazard!
Projection of splinters. Keep to a safety distance from loading and unloading equipment.

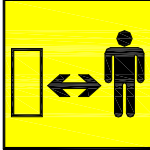



Hazard!
Keep arms well away from moving parts.



Hazard!
Keep fingers well away from cutting elements.



Hazard!
Make sure the blades have stopped completely before approaching.



Caution!
Only one person must operate the machine.



Caution!
Do not use petrol engines in closed environments.
Risk of intoxication.



Caution!
Machine running on electricity.
Risk of electrocution.

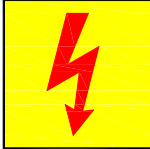

Caution!
Machine lifting point.



2. HOW TO USE AND KEEP THE INSTRUCTION MANUAL

This instruction manual is aimed at the user of the machine, the owner, the maintenance cleaning operator and the repair technician and must always be available for consultation.

The instruction manual shows the user for which the machine was designed and the machine's technical characteristics. It also supplies instructions for transport, cleaning adjustment, use, personnel information, maintenance, spare parts ordering and residual risk, and warnings with regard to operations that must be carried out with particular care.

The machine must only be used by a fully qualified and authorized person who is well acquainted with the operating principles, correct method of use and hazards.

This handbook and the CE declaration of conformity are an integral part of the machine. They must be handed over to the buyer if the machine is resold and they must always be kept for future reference until the machine is scrapped.

The instruction manual must always be available for consultation and must be kept in a dry, protected place.

In the case of loss or damage the user may request a replacement from the manufacturer, quoting the series reference, type and year of construction which are shown on the plate fixed to the bio-chopper (section 6).

The manufacturer reserves the right to update production and manual without the obligation to update earlier production and manuals.

The manufacturer is relieved from all responsibility in cases of:

- improper use of the bio-chopper;
- uses not conforming with what is expressly specified in this documentation;
- serious deficiencies in prescribed and recommended maintenance;
- unauthorised modifications or interferences;
- use of spare parts that are not original or model specific;
- total or partial failure to follow the instructions;
- force majeure;

3. IDENTIFICATION OF MAIN PARTS

1. Hopper with guards
2. Chaff cutter hopper
3. Petrol engine-electric motor
4. Wheels / axle
5. Chassis
6. Sieve lever
7. Power take-off for two-wheels tractor
8. Machine support
9. Discharge

Petrol / Electric version

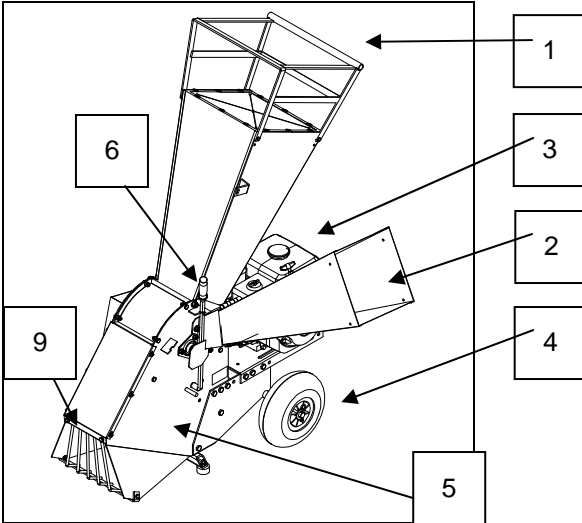

Motor-cultivator version

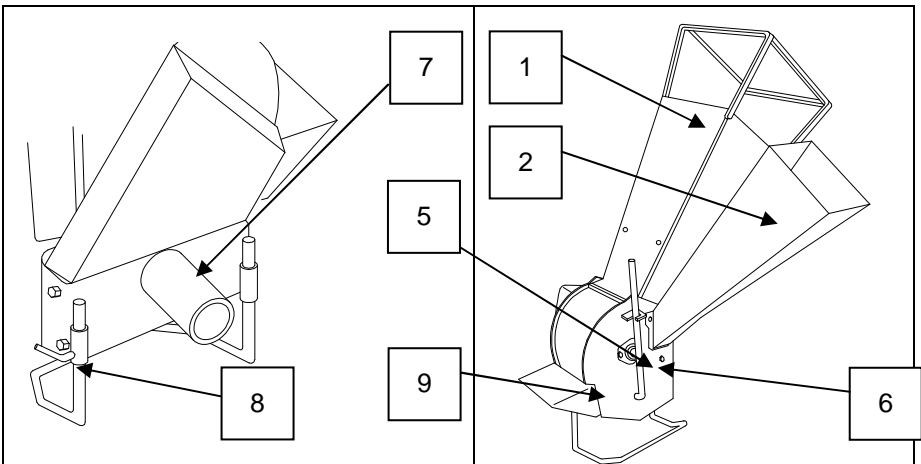

4. CORRECT USE OF THE MACHINE

The machine must only be operated by one person at a time. The operator must remain in the work position by the loading hopper while the machine is in operation.

The operator must have read and fully understood the instructions in this manual in order to use the machine correctly.

The operator must ensure that person or animals do not come within the field of action while the machine is running. Stop the machine immediately if anyone approaches.

The Caravaggi Bio 80 bioshredder is designed for shredding vegetables, leaves and wood up to 2.5 cm in the top hopper, and no later than 7 cm from the hopper side. The machine must never be used for any other purposes, such as breaking up bottles or tins.

It may be used for cutting peat and similar.

It is not suitable for chopping products other than those listed above.

To work with other products, contact the machine manufacturer or authorised dealers.

The operator must be aware of all the instructions given in the instruction manual.

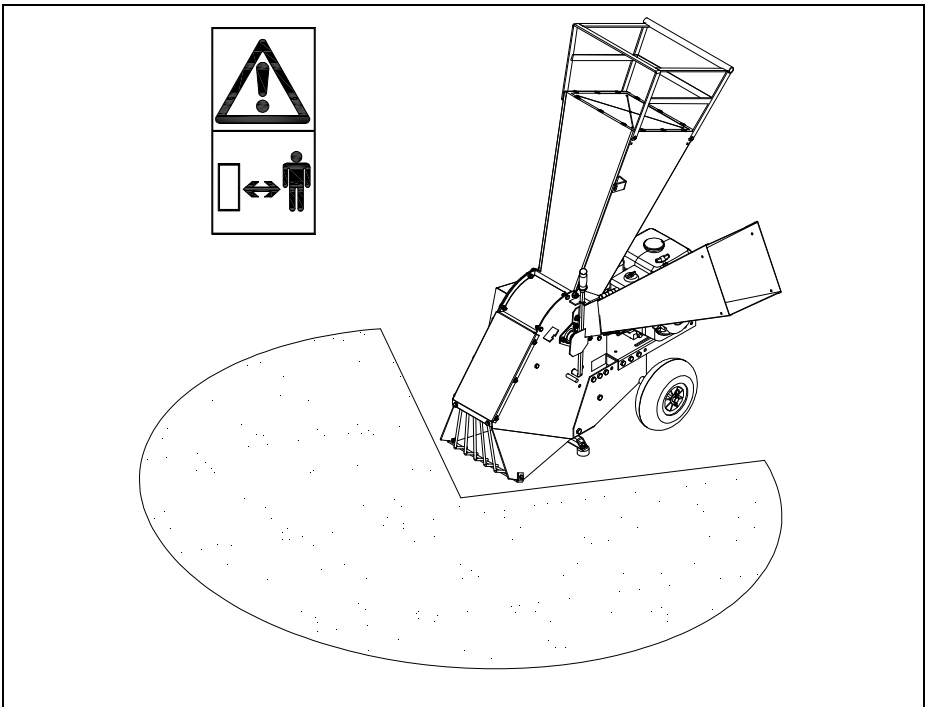

Fig. 3

5. UNPACKING AND PREPARATION

The Bio 80 bio-shredder is delivered partially dismantled. It can be arranged on pallets to facilitate handling and transport before installation, depending on the versions.

To transport the machine in these conditions it is indispensable to use a transpallet or similar with a load capacity of around 100 kilos. Avoid:

- hoisting the bio-chopper with ropes or unsuitable hoists;
- dragging the bio-chopper;
- bumps or shocks;
- exposing the machine to rain, frost or any bad weather.

On taking delivery check that the contents correspond with the delivery note.

Should damage or deformity due to transport be noted, make an immediate complaint to the carrier and advise the authorised dealer or the manufacturer.

In particular, check that:

- there are no dents, signs of bumps or deformations;
- there are no damp areas or signs that may lead to suppose that the pack has been exposed to foul weather;
- there are no signs of tampering;

After checking that transport has been carried out correctly, proceed to assembling the machine as shown in figure 5.

Electric motor or engine-operated machines are equipped with two wheels for transporting over short distances.

All the machines can be lifted and transported by means of cranes or winches, using hooks and cables, which must be approved and of an adequate capacity. Hook up to the lugs, as shown in the pictogram affixed to the machine.

Only safe hooks, such as snap hooks, must be used for lifting. Take great care and exercise extreme caution when loading and unloading the machine. These operations must only be carried out by qualified personnel (slingers, truck operators, etc.). Never pass or stand underneath the machine when it has been raised off the ground.

When the machine is being transported, it needs to be tilted slightly backwards, with one foot on the wheel axle (1) acting as a lever and holding the handle (2).

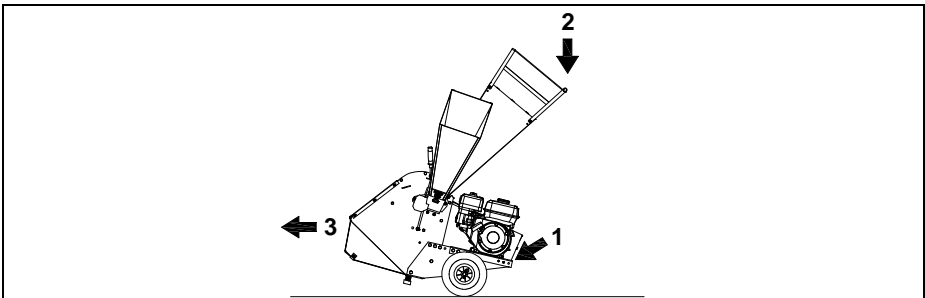

Fig.4

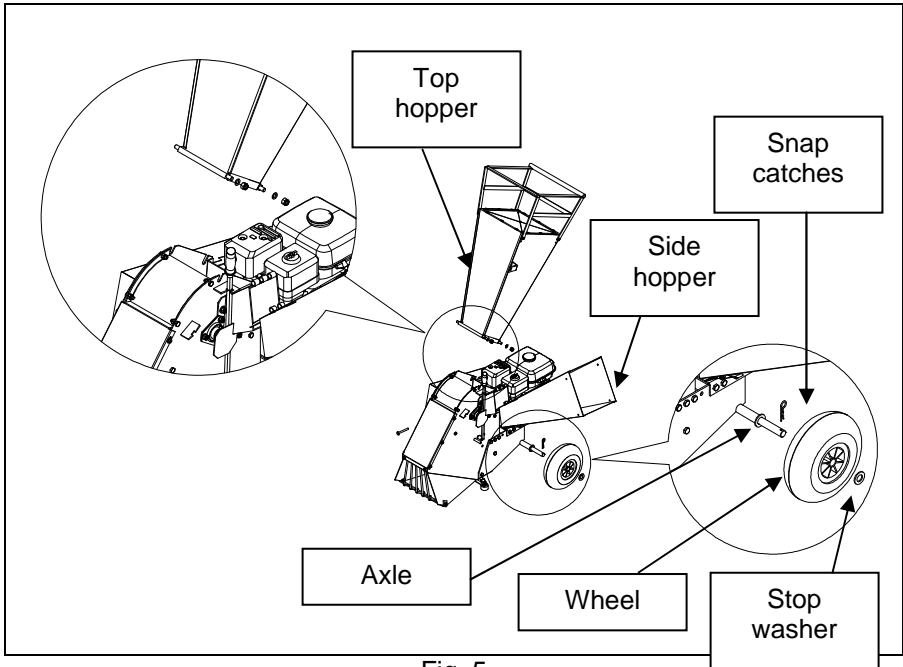

Fig. 5

- Remove all the bio-shredder components from the packing.
- Remove the snap catches from the axle and position the axle in its seat in line with the central pin.
- Mount the castors and the stop washers.
- Remount the snap catches.
- Position the hopper and tighten the screws using number 17 spanners.
- Mount the chipper hopper and insert the pin.

6. TECHNICAL CHARACTERISTICS

The EC identification plate is clearly visible on the Bio 80 bio-chopper (fig.6).

In all communications with the manufacturer state the serial number on the identification plate.

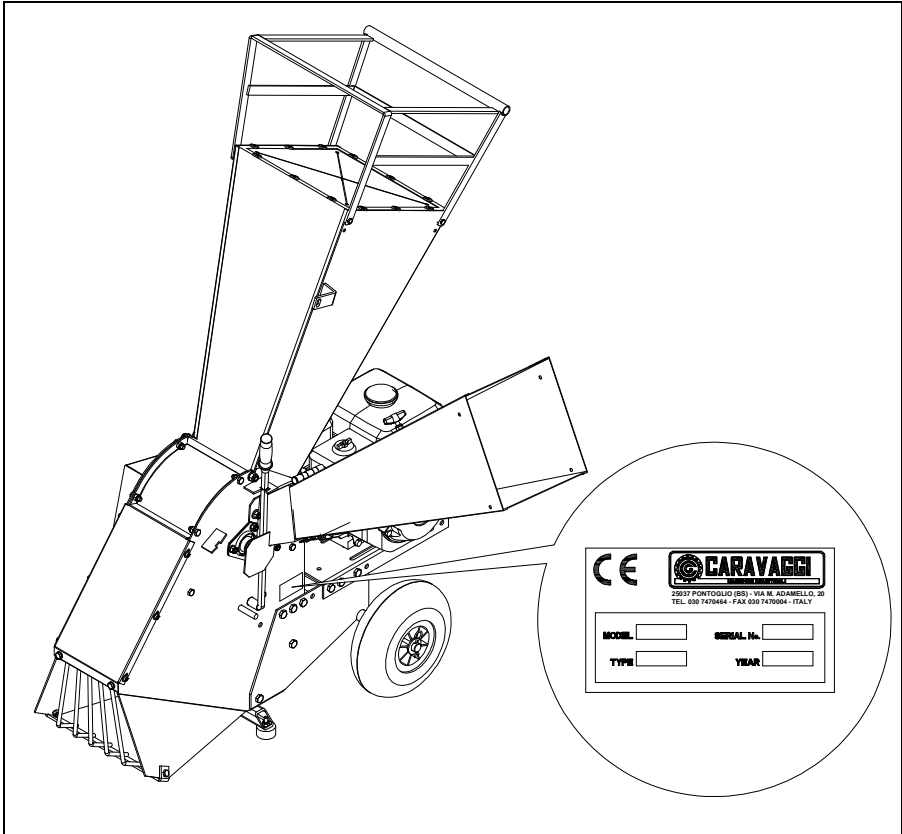

Fig. 6

Version	Power HP / kW	Supply	Prod. m ³ / h
BIO 80 E	3+4 / 2,2+2,9	Electric	2÷4*
BIO 80 B	5+9 / 3.7+6.7	Petrol	2÷4*
BIO 80 MTC	6+10 / 5.9+8.9	Motor-cultivator	2÷4*

* data depending on quality of material to be chopped and feeding speed

6.1 Overall dimensions

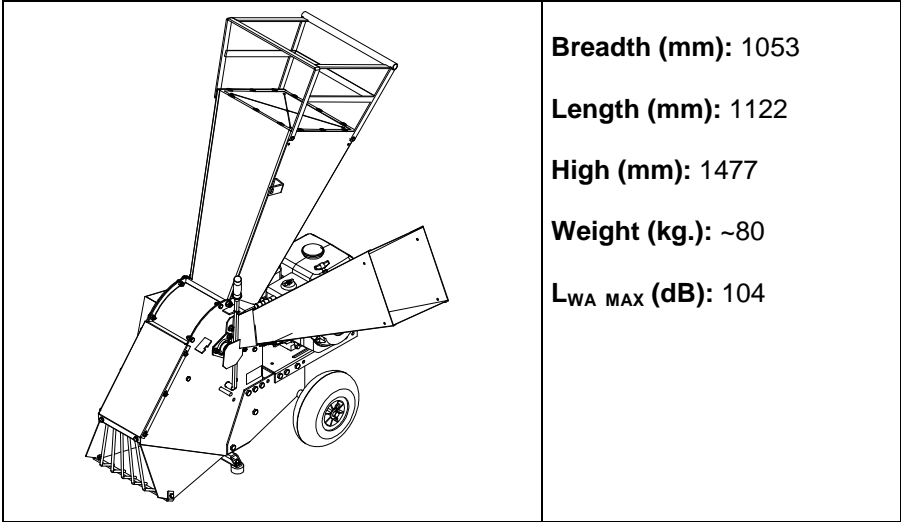

Fig. 7

7. SAFETY RULES

This handbook contains rules on how to use the machine properly and details of the hazards that may be encountered. Besides following the rules, the operator should use the machine sensibly, based on his experience, and adopt all the necessary precautions to prevent accident or injury.

The manufacturer cannot be held liable for any alterations to the machine that are not authorised in advance in writing.

The bioshredder must only be used for shredding vegetables, leaves, wood and branches. It must never be used for any other purposes, such as breaking up bottles or tins.

The machine must only be operated by a fully qualified person who is authorised to do so and is thoroughly acquainted with the operating principles and the inherent hazards.

Read through the manual before setting to work. The bioshredder must not be operated by children.

7.1 GENERAL SAFETY AND ACCIDENT PREVENTION RULES

- **Basic rules:** check the machine carefully each time before starting up.
- Besides following the recommendations contained in this handbook, it is important to follow the general safety and accident-prevention rules. Before using the machine, the operator must be fully acquainted with its features, devices, controls and functions.
- Before setting to work, make sure the shredding blades are properly secured. If they look damaged, they need to be sharpened or replaced. Mount the blades as instructed and only use original spares supplied by the manufacturer (or an authorised dealer).
- Before and after each work session, check that the guards, covers and safety devices are correctly installed and integral, and are properly secured with nuts and bolts.
- The notices on the machine provide a series of important instructions. They are there to enable you to work in complete safety. Read all the safety stickers on the machine and follow the instructions on them. If they become damaged or unreadable, they need to be cleaned or replaced in the exact position as described in the relevant section.
- The machine must only be used in an open space, on flat, firm ground that is free from obstacles. Make sure the machine is positioned stably before operating.
- Do not use the shredder in the rain.

- Anyone approaching the machine enters the danger area and hence becomes an EXPOSED PERSON. It is up to the operator to prevent other people from entering the danger area and he himself must act with extreme caution. Stop the machine immediately if anyone enters the danger area.
- Caution: the blades continue to turn for several seconds after the engine has been switched off.
- Keep the handbook readily available so that you can consult it for details of the operating cycle and maintenance instructions. If it gets lost or damaged, a replacement copy can be obtained from Caravaggi.
- The machine is designed for use by one operator only, who must always stand in front of the loading hopper.
- Do not wear items of clothing that are likely to get caught up in the mechanism, such as long wide sleeves, belts, and necklaces.
- Hearing protectors and protective goggles must always be worn when operating the machine.
- Do not leave the bioshredder unattended while it is running.
- Do not place any tools or other objects on the machine as they could damage it or injure the operator.
- Use only original spares provided by Caravaggi.

Safety rules during operation

- Check the hopper is empty before starting up the machine.
- Keep the face and hands well away from the loading hopper.
- Stand firmly on the ground while operating the machine. Never stand in a raised position to feed material into the machine.
- Before feeding in any material, make sure the hopper contains no stones, pieces of metal, tin cans, bottles or similar objects.
- Switch off the machine if there is a malfunction, abnormal vibration or any strange noises. Disconnect the power supply (spark plug in the petrol version, power plug in the electric version, cardan shaft for tractor version) and determine the cause of the problem.
- Never attempt to move the machine while it is running.

7.2 SPECIFIC SAFETY AND ACCIDENT PREVENTION RULES

7.2.1 Motor-cultivator models

- Any maintenance, adjustment or cleaning operations (e.g. removal of foreign bodies from the hoppers) must be done with the machine standing firmly on the ground, the motor-cultivator engine switched off, the hand brake engaged, and the ignition switched off and the key removed.
- Never stand between the motor-cultivator and the machine when the engine is on and the power take-off connected.
- Make sure the drive shaft guards are in good condition and in place.
- Any damaged or inefficient guards must be replaced immediately.
- Never use the machine in an enclosed or poorly ventilated room (even if the doors and windows are open) because the exhaust fumes are highly toxic.
- Before disconnecting the machine from the motor-cultivator, make sure they are standing still on firm, flat ground.

7.2.2 Electric version

- Maintenance, adjustment and cleaning operations (e.g. removing foreign bodies from the hopper) must be done with the machine resting firmly on the ground, switched off and disconnected from the power supply.
- The machine complies with the general principles of electrical safety. This means that if any changes are made to the structure or components, this will alter the characteristics of the system, which will no longer comply with the safety requirements.
- Make sure the controls and cables are integral and in good condition.
- The electrical protection rating is IP54.

7.2.3 Petrol version

- If there is a malfunction, and prior to any maintenance, adjustment and cleaning operations (e.g. removing foreign bodies from the hopper), switch off the motor and remove the spark plug cable.
- Before setting to work, read through and follow the instructions in this handbook and the accompanying engine handbook.
- Never use the machine in enclosed or poorly ventilated areas (even if the doors and windows are open), as the exhaust fumes are toxic.
- Avoid smoking and lighting flames when filling with petrol.
- Always fill the fuel tank in an open area with the engine switched off. Remember that petrol is highly flammable and explosive under certain conditions. Fuel must be stored in suitable canisters.
- Never place anything on the engine as it could catch fire.
- Never remove the fuel tank cap or top up with petrol with the engine running or when it is still hot.
- If any petrol gets spilt, do not attempt to start the engine immediately.
- The exhaust pipe gets very hot when the engine is running and remains hot for some time after it is switched off. Never touch the exhaust pipe. Keep to a safety distance.

8. START UP

Caution! Before starting up the engine/motor check that the bio-chopper is on a stable surface and that there are no animals or unauthorised persons in the work zone.

Petrol engine version

- Read the engine/motor manufacturer's instruction book carefully.
- Check that there is oil and fuel in the tank. Fill if necessary.
- Put the selector at position "I" (Start) (fig.8). Grasp the starting knob (fig.9) and pull the cord without force until you feel the resistance caused by compression, release the knob and then give a sharp tug to start the engine.
- Before beginning work let the engine idle for about 1 minute then take it to maximum revs (using accelerator lever) and proceed with normal use.

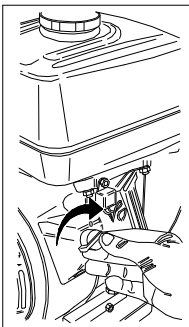

Fig. 8

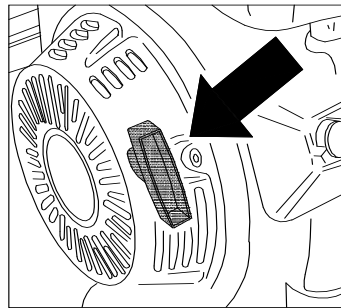

Fig. 9

Electric motor version

- Make sure the mains voltage corresponds to the motor rated voltage (check the rating plate on the motor) .
- Check that the power supply cable is connected then press the start/stop button.
- Regularly check that the power supply cable is in perfect condition. Never repair a damaged cable with insulating tape or thermal lamps.
- For the power supply conductor use only standardised rubber cable of the type 05RN-F in accordance with DIN 57282/VDE 0282.
- Hook-up plugs must be in rubber or rubber covered.

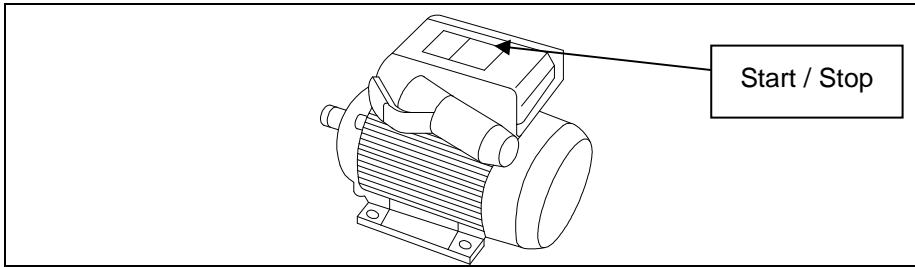

Fig. 10

Version for connecting to a motor-cultivator

- The bioshreder must be connected to the motor-cultivator with the engine switched off.
- Check that the coupling on the bioshreder is suitable for use with the motor-cultivator.
- The motor-cultivator power takeoff coupling and the bioshreder must be correctly aligned prior to connection.
- Connect the shaft of the bioshreder to the motor-cultivator power takeoff.
- Insert the safety pin in the sleeve and lock it with the split pin (R).
- Check that the motor-cultivator power takeoff rotates in the same direction as the bioshreder rotor.
- Caravaggi S.r.l. declines all liability for damage or injury caused by incorrect motor cultivator-bioshreder connection and operation.

Functioning

Having correctly prepared the bio-chopper you can now proceed to working the material to be chopped.

Upper hopper

Load trimming and foliage into the upper loading hopper, taking account of available power in function of the model you possess (fig. 11).

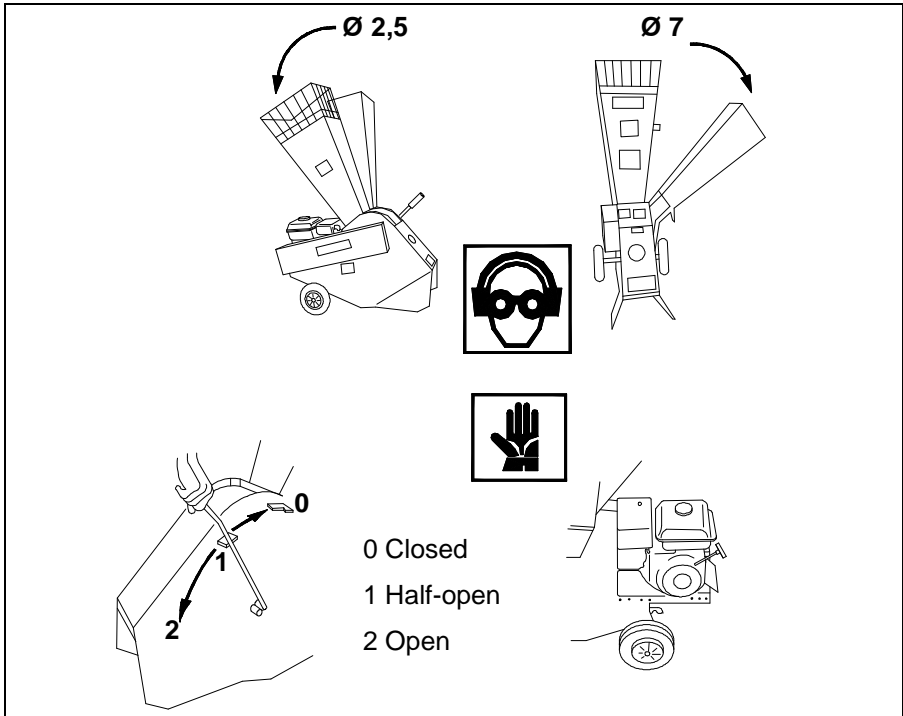

Fig. 11

Caution! Take the material to the hopper mouth and let it fall in.

Never put hands and arms in to push material into the hopper!

The material that can be worked and chopped in this hopper must not exceed 2,5 cm diameter.

To avoid the danger of intoxication from fumes, machines with internal combustion engines should never be used in closed environments.

Side hopper chaff cutter

Assemble this hopper (as shown in section 3) ensuring that the closure hook is well fixed.

Use the side hopper for working large size material (branches of up to 7cm diameter).

If the blades undergo heavy shock and function in an anomalous manner, stop the engine, remove the spark plug hood and request expert advice.

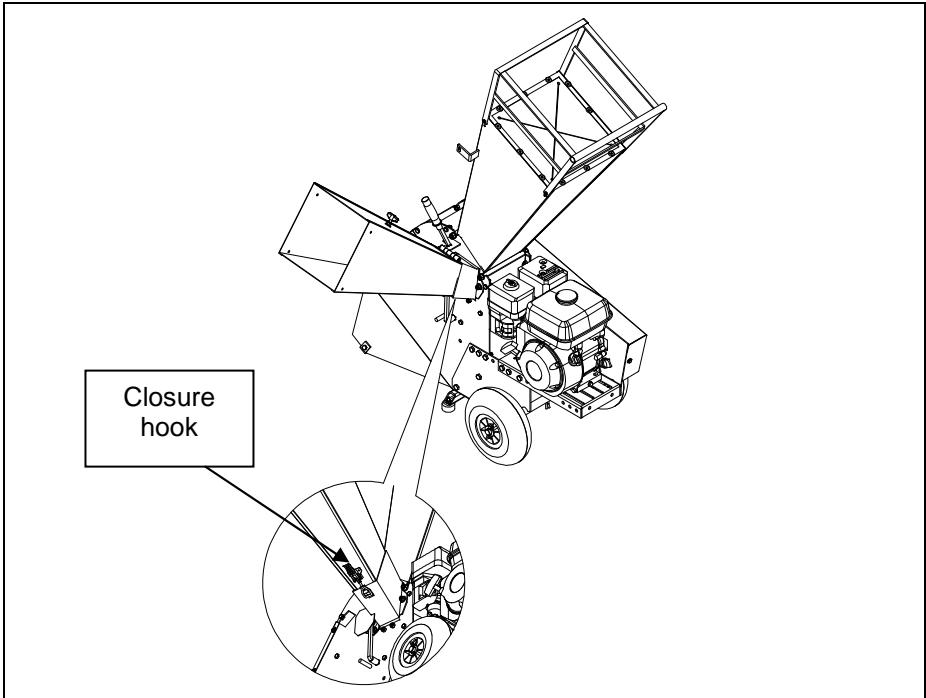

Fig.12

Maintenance and storage

- Keep all nuts, bolts and screws perfectly tightened in order to work in safe conditions.
- For safety reasons promptly replace worn or damage parts.
- To protect hands during dismantling and assembly of the blades, wear suitable protective gloves.

9. MAINTENANCE

Caution! Before proceeding with any maintenance operation switch off the engine / motor and in any case ensure that there is no possibility of the machine functioning. Suitable gloves are obligatory for all maintenance operations.

To facilitate transportation of the Bio 80 bio-chopper its overall size can be reduced by folding the side hopper inwards as follow:

- Unhook the closure hook.
- Fold the chaff cutter hopper immobilising it with wing nut 1.

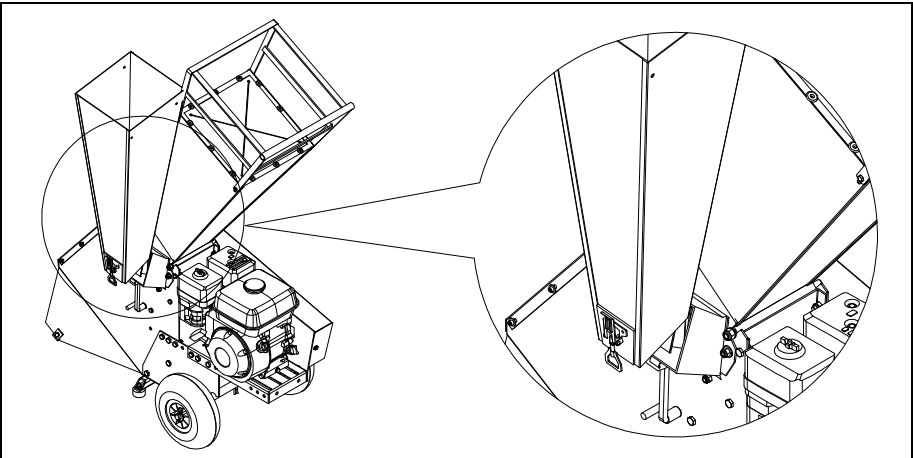
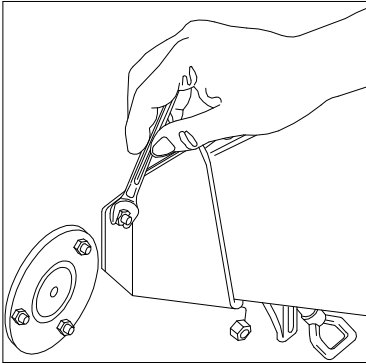

Fig. 13

9.1 Blade replacement



- Remove the side hopper by unscrewing the 3 nuts as shown in fig. 14.

Fig. 14

- Unscrew the retaining screws and remove the upper hopper.
- Insert the keys in the two apertures (fig. 15) and remove the blade.
- Proceed with sharpening the blade or, in the case of replacement, request an original spare part from the manufacturer and reassemble following the instructions in reverse order.

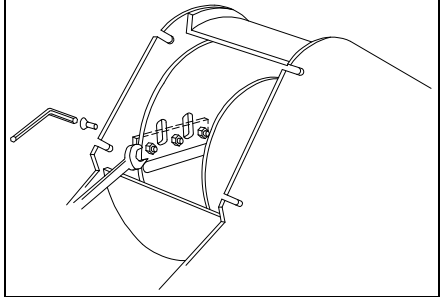
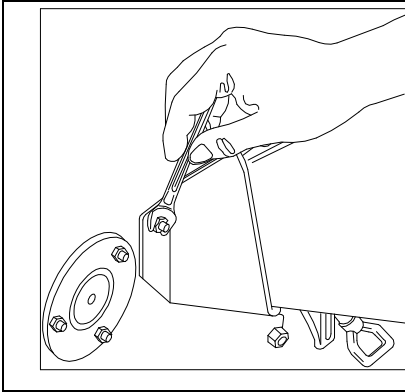

Fig. 15

9.2 Counter-blade replacement



- Remove the side hopper by unscrewing the 3 nuts as shown in fig. 16.

Fig. 16

- Unscrew the retaining screws and remove the upper hopper.
- Insert the keys in the two apertures (fig. 17) and remove the counter-blade.
- Proceed with sharpening the counter-blade or, in the case of replacement, request an original spare part from the manufacturer and reassemble following the instructions in reverse order.

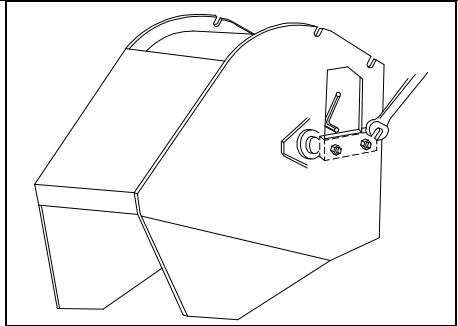

Fig. 17

Caution! For this operation the blade must be removed as indicated at point 9.1.

9.3 Breaker bar removal, inversion and replacement

- Unscrew the retaining screws and remove the upper hopper
- Remove the side hopper by unscrewing the 3 nuts (fig. 14).
- Remove the transmission belt casing.
- Remove the galvanised hole plate.
- Manually turn the rotor to align the cutter shaft with the aperture.
- Insert the Allen key on one side and number 13 spanner on the other. Unscrew the locking screw and pull out the rod, collecting the spacers as you do so.
- If necessary replace the breaker bars. Take care to replace the previously removed spacers in the same position on the cutter shaft.

Caution! Partial replacement of the breaker bars must be carried out respecting the opposite position for balancing.

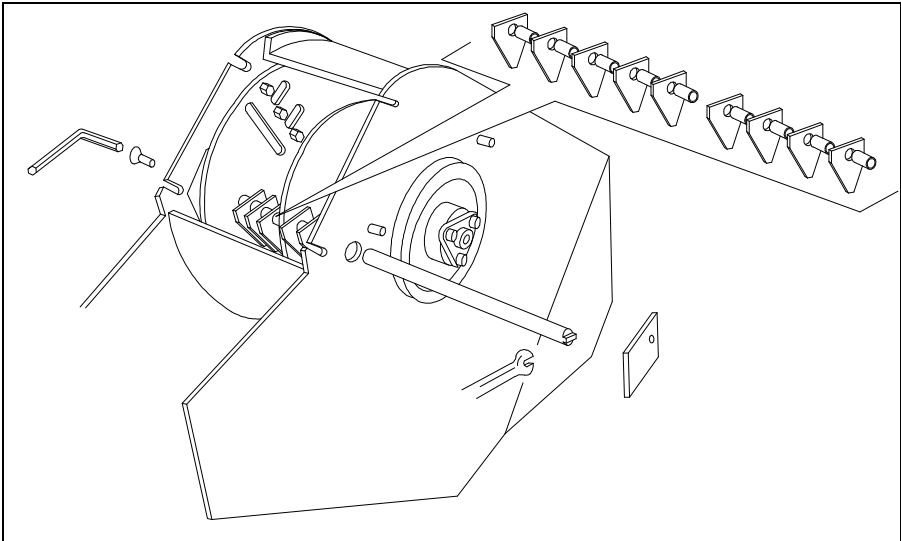

Fig. 18

9.4 Replacing the sieve

- Remove the two nuts and detach the sieve from the lever.
- Remove the sieve.
- Mount the new sieve and the lever, then tighten the nuts.
- The lever can be used partially opened out for shredding green or wet material (Fig. 11).

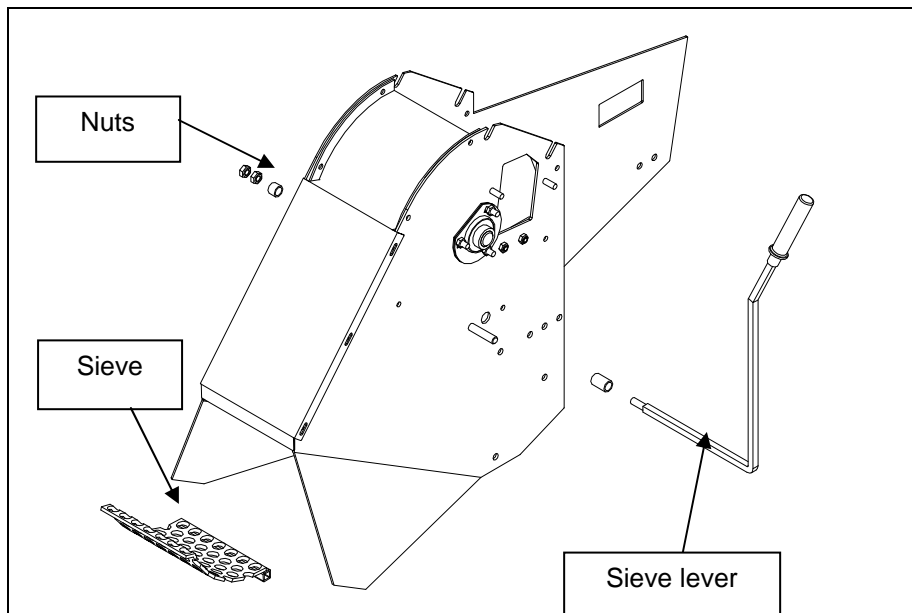

Fig. 19

9.5 Replacing and tensioning the drive belt

Petrol and electric version

- Remove the belt guard.
- Remove the belt and mount a new one.
- To tension the belt unscrew the 4 screws of the motor and pull it in the direction shown by the arrow. Then tighten the screws but avoid overstretching the belt.
- Remount the guard.

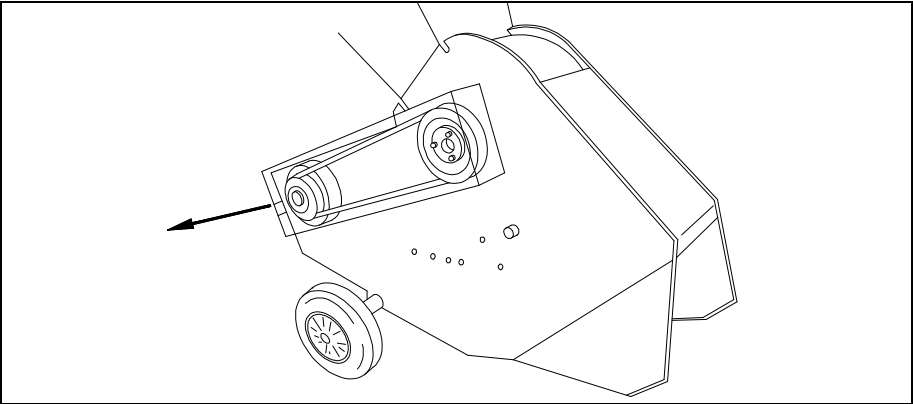

Fig. 20

Motor-cultivator version

- Remove the belt guard.
- Remove the belt and mount a new one.
- To tension the belt unscrew the 4 screws securing it to the motor-cultivator plate and pull the plate in the direction shown by the arrow.
- Remount the guard.

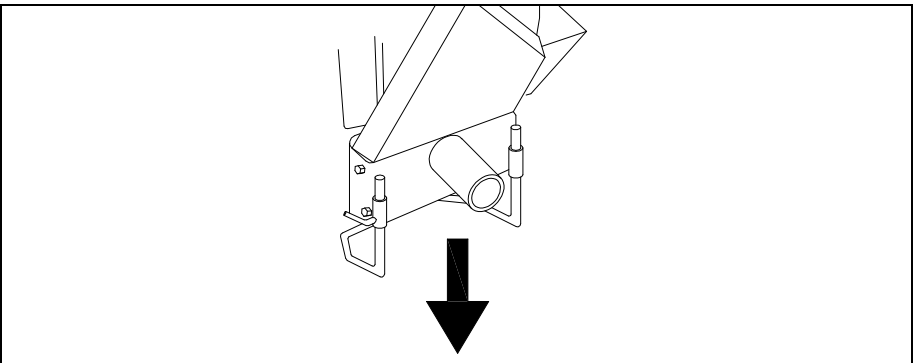

Fig. 21

9.6 Routine maintenance

	Beginning of season	Before each job	End of season
Check engine oil level		◆	
Check screws, tightness, casing, hopper, etc.	◆	◆	
Check belt tension and state of wear	◆	◆	
Check wear on cutters	◆		◆
Check wear on blade	◆		◆
Check wear on counter-blade	◆		◆
Check hopper rubber protection	◆	◆	◆
Clean machine			◆
Check wear on bearings and transmission shafts	◆		◆

10. TROUBLESHOOTING-REMEDIES

Troubleshooting	Remedies
The bio-chopper does not start	<p>Check belt tension and condition, blocked pulleys, PTO or gears.</p> <p>Check cutters, blade, counter-blade and presence of material in the milling chamber.</p> <p>Check state of engine/motor (consult the instruction manual supplied).</p>
Difficult start-up or loss of power	<p>Check belt tension and condition, blocked pulleys, PTO or gears.</p> <p>Check state of engine/motor (consult the instruction manual supplied).</p>
The bio-chopper loses revs and functions irregularly	<p>Check belt tension and condition, blocked pulleys, PTO or gears.</p> <p>Check cutters, blade, counter-blade and presence of material in the milling chamber.</p> <p>Check the sieve which should be free of blockages.</p> <p>Check state of engine/motor (consult the instruction manual supplied).</p> <p>Examine the material being chopped at the moment of breakdown.</p>
Excessive vibration	<p>Check cutters, blade, counter-blade and presence of material in the milling chamber.</p>
Drop in quality of output material	<p>Check belt tension and condition, blocked pulleys, PTO or gears.</p> <p>Check state of engine/motor (consult the instruction manual supplied).</p>
The hopper rejects the material	<p>Check cutters, blade, counter-blade and presence of material in the milling chamber.</p> <p>Check state of engine/motor (consult the instruction manual supplied).</p> <p>Check state of wear on hopper rubber protection .</p>

11. GUARANTEE

1. The Manufacturer hereby guarantees its BIO-SHREDDERS against breakage caused by faulty materials or workmanship.
2. This warranty is valid for the first owner only for 12 months as from the date of purchase and/or delivery.
3. The Manufacturer is entitled to inspect the Bio-Shredder and any components for which a claim has been made under the guarantee, in order to determine the validity of the claim.
4. This warranty covers replacements free of charge only of components found to be defective due to faulty materials or workmanship under the guarantee period.
5. This warranty does not cover reimbursement for labour, consumables or transport charges for repairs under guarantee.

THIS WARRANTY DOES NOT APPLY IN THE FOLLOWING CASES

1. The Manufacturer may in no way held liable for general damage, including damage or injury, loss due to halts in production, loss of earnings, leasing costs or any moral or commercial damage.
2. All claims concerning motors or engines mounted on Bio-Shredder will be handled by the relevant Manufacturers' after-sales service.
3. This warranty does not cover damage caused by misuse, abuse, insufficient maintenance, accident or damage caused during transport.
4. Parts which are subject to wear, such as hammers, blades, anvil blades, etc. are not covered under this guarantee.
5. All expenses for setting the machine to work will be charged to the distributor or dealer.
6. This warranty is not valid if the repairs, maintenance or modifications are performed by an unauthorised persons or dealers.
7. The owner is responsible for routine maintenance and settings, which are thus excluded herefrom.
8. The use or fitting of components and accessories that are not original will immediately invalidate this warranty.

PROCEDURE FOR MAKING CLAIMS UNDER THIS WARRANTY

If the Bio-Shredder is found to be defective due to faults material or workmanship, you are required to send the Manufacturer a written claim and proceed as follows:

1. The machine must be returned to the Seller or the authorised CARAVAGGI importer.
2. You are required to present the guarantee duly filled in or the bill, if this is not available.
3. The claim will be completed by the Dealer, who will forward it to the Manufacturer.
4. The Manufacturer alone reserves the right to determine whether to accept the claim or otherwise.

Any disputes will be put before the Court of Brescia, Italy.

CARAVAGGI MACCHINE INDUSTRIALI
Via Monte Adamello, 20
25037 Pontoglio (BS) - ITALY
Tel. +39 030 7470464 - Fax +39 030 7470004
Internet <http://www.caravaggi.com>
E-mail info@caravaggi.com

Rev.1-2012